

MLA-JL-01 Industrial Linear Actuator

2026 Catalog



• Glossary of Terms

Stroke	How far the rod extends outwards from the body. The difference between fully extended length and fully retracted length. (Customizable)
Installation Length	The length of unit when fully closed. (Customizable)
Front Mounting End	Optional.
Rear Mounting End	Optional.
Mounting Holes	Can be rotated by 90°.
Dynamic Force	The max. force the actuator can carry while it is moving.
Self-locking	The max. force the actuator can hold when it is stopped.
Weather Protection	IPXX. The first digit: Dust Protection. The Second Digit: Liquids Protection. Please refer to [Table 1.]
Duty Cycle	Continuous working time “a”, rest time “b”. Duty Cycle is a/(a+b)x100%. Please refer to [Table 1.]
Speed	Includes free-load speed and full load speed.
Hall Sensor	Provides pulse signals. Displacement measurement is achieved through pulse counting, and the phase difference of the waveform can be used to identify the rotation direction of motor. Check [Table 1] to see if it is available.
Potentiometer	Potentiometer is a three-terminal variable resistor with a rotating contact which is used to measure the displacement of actuators. Check [Table 1] to see if it is available.
Manual Override	Can be used to extend or retract the actuator when there is no power in an emergency situation. Check [Table 1] for availability.

• General Specifications

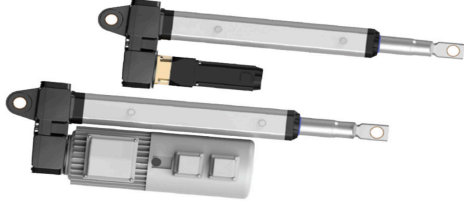
Color	<input checked="" type="checkbox"/> Silver	<input type="checkbox"/> Black	<input type="checkbox"/> Custom						
Lead Screw	<input type="checkbox"/> Acme Screw	<input checked="" type="checkbox"/> Ball Screw							
Operation Mode	<input checked="" type="checkbox"/> Electrical	<input type="checkbox"/> Electrical + Manual							
Application	<input checked="" type="checkbox"/> Industrial	<input type="checkbox"/> Furniture	<input type="checkbox"/> Medical						
Operational Temp.	<input type="checkbox"/> 5°C to 40°C	<input checked="" type="checkbox"/> -15°C to 40°C	<input type="checkbox"/> -40°C to 65°C						
Operating Noise	<input type="checkbox"/> ≤45dB	<input type="checkbox"/> ≤50dB	<input checked="" type="checkbox"/> ≤65dB						
Stroke Range	<input checked="" type="checkbox"/> 100 to 600mm	<input checked="" type="checkbox"/> 600 to 1,000mm							
Dynamic Load	≤1,200N	≤2,000N	≤4,000N				≤10,000N	≤12,000N	<input checked="" type="checkbox"/> ≤20,000N
Duty Cycle	10%	<input checked="" type="checkbox"/> 20%	25%				<input checked="" type="checkbox"/> ≤50%	<input checked="" type="checkbox"/> 100%	
Motor Type	<input checked="" type="checkbox"/> Brushed DC	<input type="checkbox"/> Stepper Motor	<input checked="" type="checkbox"/> Brushless DC				<input checked="" type="checkbox"/> Servo Motor	<input checked="" type="checkbox"/> 3-Phase AC	
Overload Protection	<input checked="" type="checkbox"/> None	<input type="checkbox"/> Clutch	<input type="checkbox"/> Electronic	<input type="checkbox"/> Thermistor					
Weather Protection	<input type="checkbox"/> IP20	<input type="checkbox"/> IP43	<input type="checkbox"/> IP54	<input checked="" type="checkbox"/> IP55	IP66	<input type="checkbox"/> IP69K			
Position Feedback	<input checked="" type="checkbox"/> Internal Limit Switch	<input type="checkbox"/> Endstop Signal	<input type="checkbox"/> Hall Sensor	<input type="checkbox"/> Potentiometer	<input type="checkbox"/> Encoder	<input type="checkbox"/> Reed Switches			
Input Voltage	<input type="checkbox"/> 12VDC	<input checked="" type="checkbox"/> 24VDC	<input type="checkbox"/> 36VDC	<input checked="" type="checkbox"/> 48VDC	<input checked="" type="checkbox"/> 220VAC	<input checked="" type="checkbox"/> 380VAC			
Additional Features	Ability to Synchronize up to 4 Motors		CE Certification						

[Table 1]

Options for MLA-JL-01 Available Other Models

• Technical Parameters

Please contact cs@machmo.com if none of the options below meet your requirements.

1. Three-phase AC Motor

Motor Type	Code	Synchronous Pulley Speed Ratio	Reduction Ratio	Speed +/-10% (mm/sec) (*See Note 1)		Max. Dynamic Load (N)	Max. Self-Locking Load (N)	No Load Current (A)	Full Load Current (A)	Ball Screw	Three-phase Frequency Conversion Motor Configuration
				Free Load	Full Load						
3-Phase AC	A	20:40	3:1	25	24	20,000	22,000	0.4	2.2	GQ 3206	380 VAC, 0.75KW, 50Hz, 4 Poles, 1,500 rpm, Frequency Range 30 -70Hz
	B	27:34	3:1	40	38	10,000	12,000	0.4	1.7	GQ 3206	
	C	20:40	None	75	72.5	5,000	7,000	0.4	1.6	GQ 3206	

*Note 1: When fully loaded in normal temperature environment, duty cycle is 100%.

[Table 2]

2. Servo AC Motor

Motor Type	Code	Synchronous Pulley Speed Ratio	Reduction Ratio	Speed +/-10% (mm/sec) (*See Note 2)		Max. Dynamic Load (N)	Max. Self-Locking Load (N)	No Load Current (A)	Full Load Current (A)	Ball Screw	Three-phase Frequency Conversion Motor Configuration
				Free Load	Full Load						
Servo AC	E	20:40	6:1	25	24	20,000	22,000	0.7	3.7	GQ 3206	220VAC, 0.75KW, 50Hz, 3,000 rpm
	F	20:40	3:1	50	49	10,000	12,000	0.7	3.7	GQ 3206	
	G	27:34	3:1	80	79	5,000	7,000	0.7	3.0	GQ 3206	

*Note 2: When fully loaded in normal temperature environment, duty cycle is 100%.

[Table 3]

3. Brushless DC Motor

Motor Type	Code	Synchronous Pulley Speed Ratio	Motor Output Speed (RPM)	Speed +/-10% (mm/sec) (*See Note 3)		Max. Dynamic Load (N)	Max. Self-Locking Load (N)	Voltage (VDC)	No Load Current (A)	Full Load Current (A)	Ball Screw
				Free Load	Full Load						
Brushless DC	H	20:40	500	25	24	20,000	22,000	48	7	16.8	GQ 3206
	I	20:40	1,000	50	48	10,000	12,000	48	7	16.8	GQ 3206
	J	20:40	2,000	100	96	5,000	7,000	48	7	16.8	GQ 3206

*Note 3: When fully loaded in normal temperature environment, duty cycle is 50%.

[Table 4]

4. Brushed DC Motor - 48V

Motor Type	Code	Synchronous Pulley Speed Ratio	Motor Output Speed (RPM)	Speed +/-10% (mm/sec) (*See Note 4)		Max. Dynamic Load (N)	Max. Self-Locking Load (N)	Voltage (VDC)	No Load Current (A)	Full Load Current (A)	Ball Screw
				Free Load	Full Load						
Brushed DC	K	20:40	500	25	24	20,000	22,000	48	7	16.8	GQ 3206
	L	20:40	1,000	50	48	10,000	12,000	48	7	16.8	GQ 3206
	M	20:40	2,000	100	96	5,000	7,000	48	7	16.8	GQ 3206

*Note 4: When fully loaded in normal temperature environment, duty cycle is 20%.

[Table 5]

5. Brushed DC Motor - 24V

Motor Type	Code	Synchronous Pulley Speed Ratio	Motor Output Speed (RPM)	Speed +/-10% (mm/sec) (*See Note 5)		Max. Dynamic Load (N)	Max. Self-Locking Load (N)	Voltage (VDC)	No Load Current (A)	Full Load Current (A)	Ball Screw
				Free Load	Full Load						
Brushed DC	N	20:40	500	25	24	20,000	22,000	24	3.1	33.6	GQ 3206
	O	20:40	1,000	50	48	10,000	12,000	24	3.1	33.6	GQ 3206
	P	20:40	2,000	100	96	5,000	7,000	24	3.1	33.6	GQ 3206

*Note 5: When fully loaded in normal temperature environment, duty cycle is 20%.

[Table 6]

• 1. Three-phase AC Motor - Product Dimensions

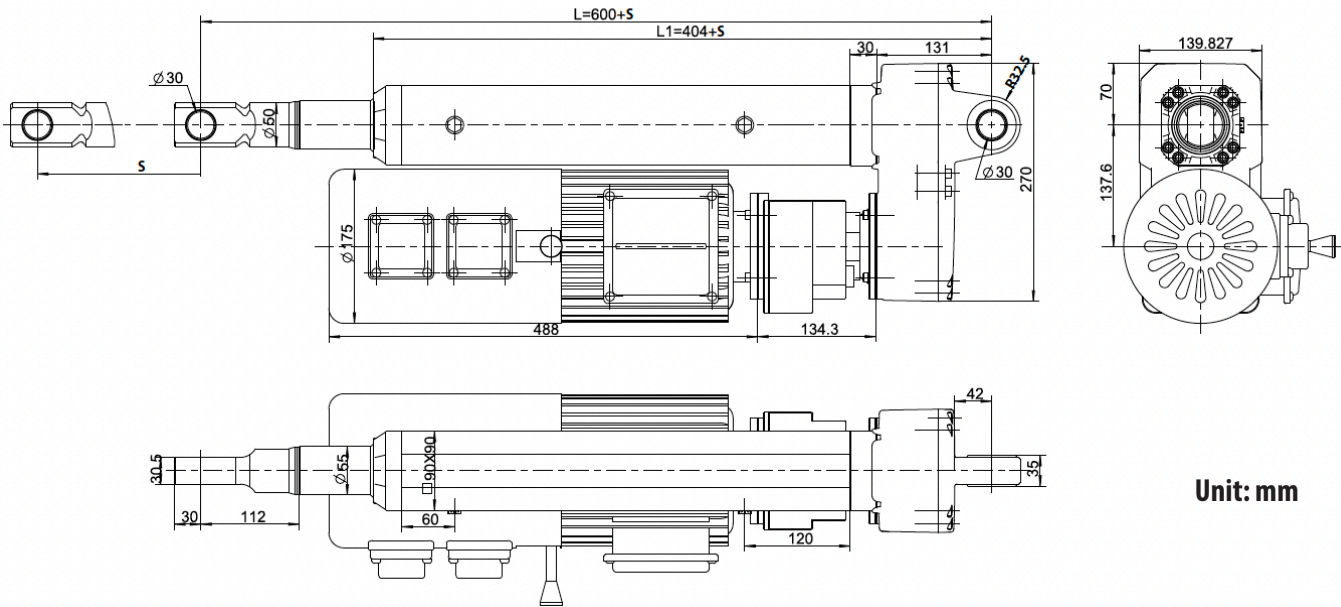

Unit: mm

Front mounting hole in drawing shown at 0°, it can be customized to rotate 90°.

How to Calculate "Installation Length":

S = Stroke, L = Installation Length
 $L \geq S + 600\text{mm} (\geq 800\text{mm})$

Stroke VS. Installation Length

Stroke (S) (mm)	Installation Length (L) (mm)
100 - 1,000	+600, ≥800mm

• 2. Servo AC Motor - Product Dimensions

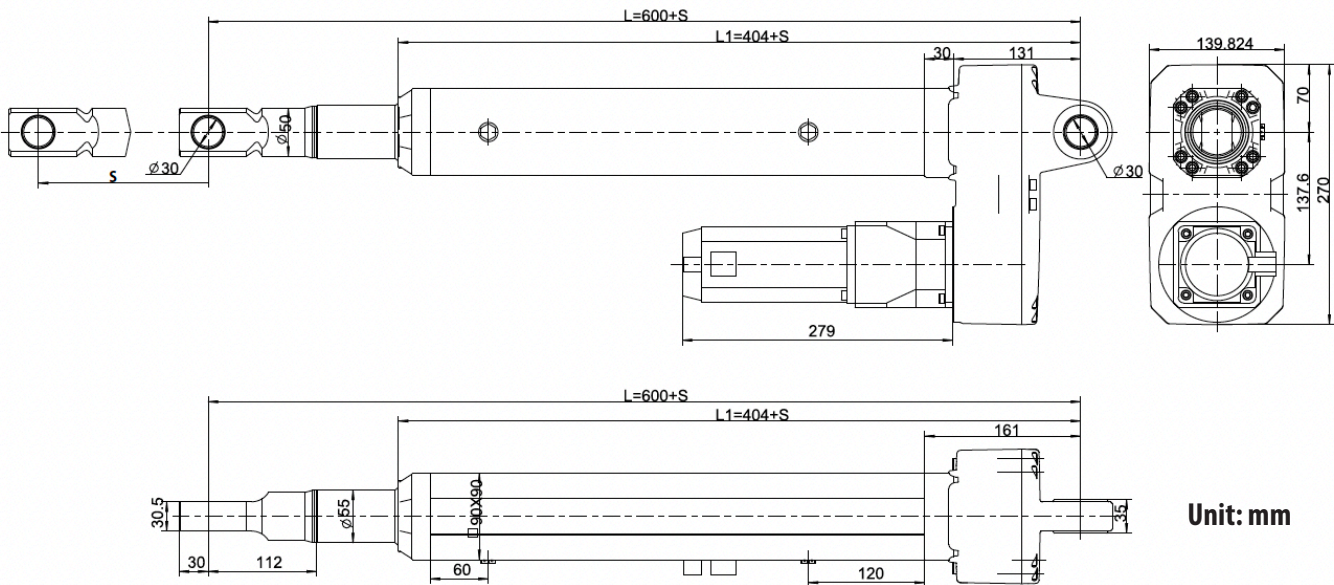

Unit: mm

Front mounting hole in drawing shown at 0°, it can be customized to rotate 90°.

How to Calculate "Installation Length":

S = Stroke, L = Installation Length
 $L \geq S + 600\text{mm} (\geq 700\text{mm})$

Stroke VS. Installation Length

Stroke (S) (mm)	Installation Length (L) (mm)
100 - 1,000	+600, ≥700mm

• 3. Brushless DC 48V - Product Dimensions

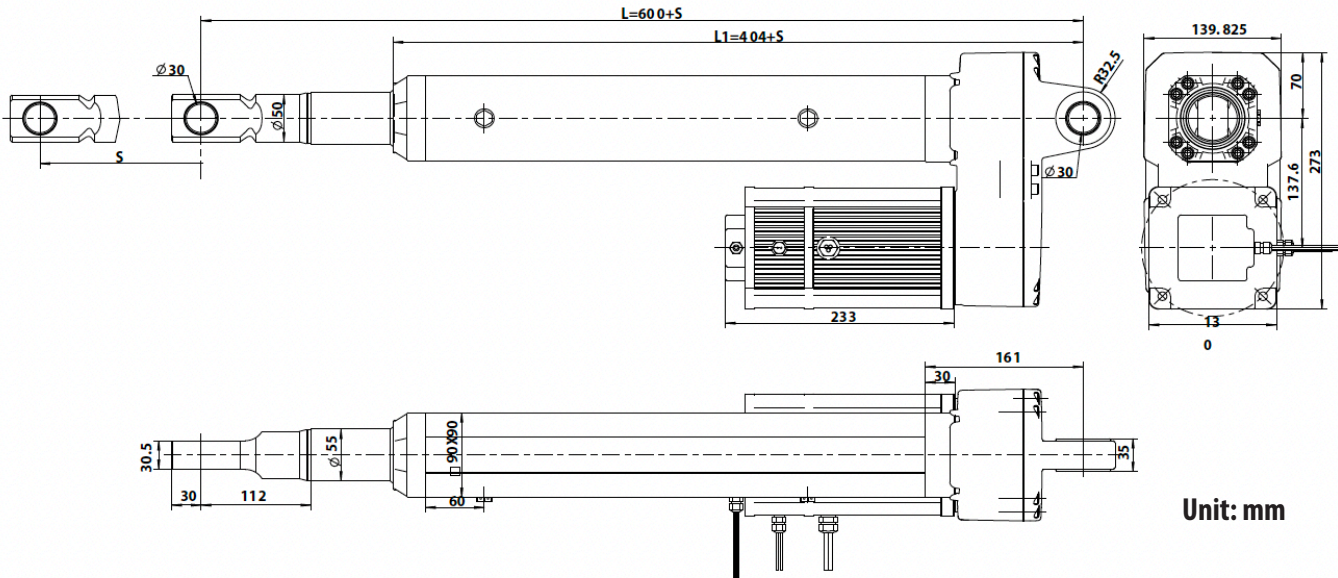

Unit: mm

Front mounting hole in drawing shown at 0°, it can be customized to rotate 90°.

How to Calculate "Installation Length":

S = Stroke, L = Installation Length
 $L \geq S + 600\text{mm} (\geq 700\text{mm})$

Stroke VS. Installation Length

Stroke (S) (mm)	Installation Length (L) (mm)
100 - 1,000	+600, $\geq 700\text{mm}$

• 4. Brushed DC 48V - Product Dimensions

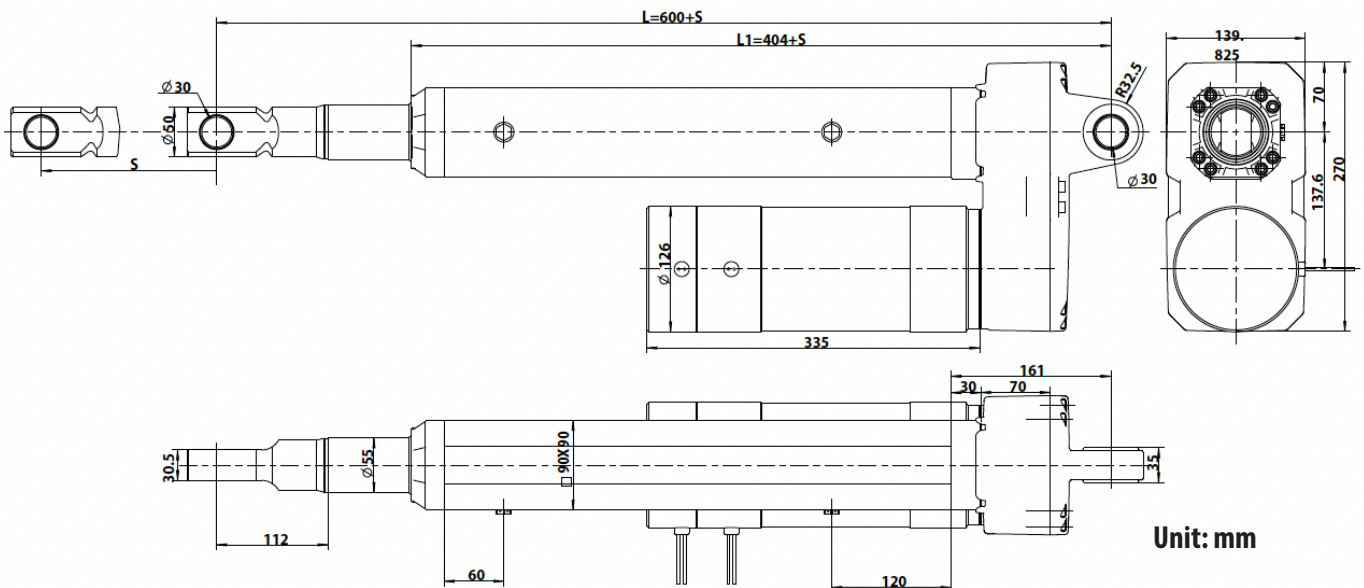

Unit: mm

Fronting mounting hole in drawing shown at 0°, it can be customized to rotate 90°.

How to Calculate "Installation Length":

S = Stroke, L = Installation Length
 $L \geq S + 600\text{mm} (\geq 700\text{mm})$

Stroke VS. Installation Length

Stroke (S) (mm)	Installation Length (L) (mm)
100 - 1,000	+600, $\geq 700\text{mm}$

• 5. Brushed DC 24V - Product Dimensions

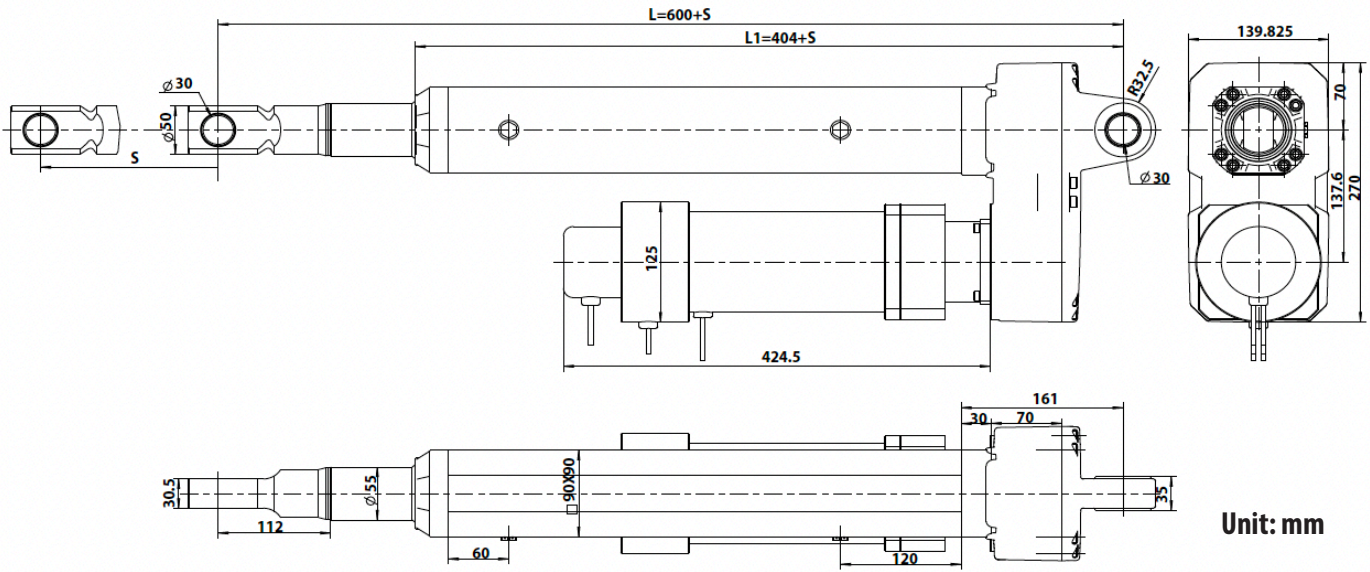

Front mounting hole in drawing shown at 0°, it can be customized to rotate 90°.

How to Calculate "Installation Length":

$S = \text{Stroke}$, $L = \text{Installation Length}$
 $L \geq S + 600\text{mm} (\geq 700\text{mm})$

Stroke VS. Installation Length

Stroke (S) (mm)	Installation Length (L) (mm)
100 - 1,000	+600, $\geq 700\text{mm}$

• Product Inquiry Table

Specification	Available Options			
Voltage	1 = 3-Phase AC	2 = Servo AC	3 = 48V BLDC	4 = 48V Brushed DC
	5 = 24V Brushed DC			
Load and Speed	See [Tables 2-6]			
Stroke (mm)	Please contact cs@machmo.com if required stroke is out of range.			
Installation Length (mm)	See Pages 4-5			
Mounting Hole Direction	Front 1 = 90°	Front 2 = 0°	Rear 1 = 90°	Rear 2 = 0°
Signal Feedback	0 = None			
Cable Length	1 = 500mm	2 = 1,000mm	3 = 2,000mm	X = Custom
Working Temperature	1 = -15°C ~ 40°C			
Working Frequency	Estimated Work Cycles Per Day			
End Use	Indoor or Outdoor?			

Selection

Application