

MLA-J Industrial Linear Actuator

2026 Catalog

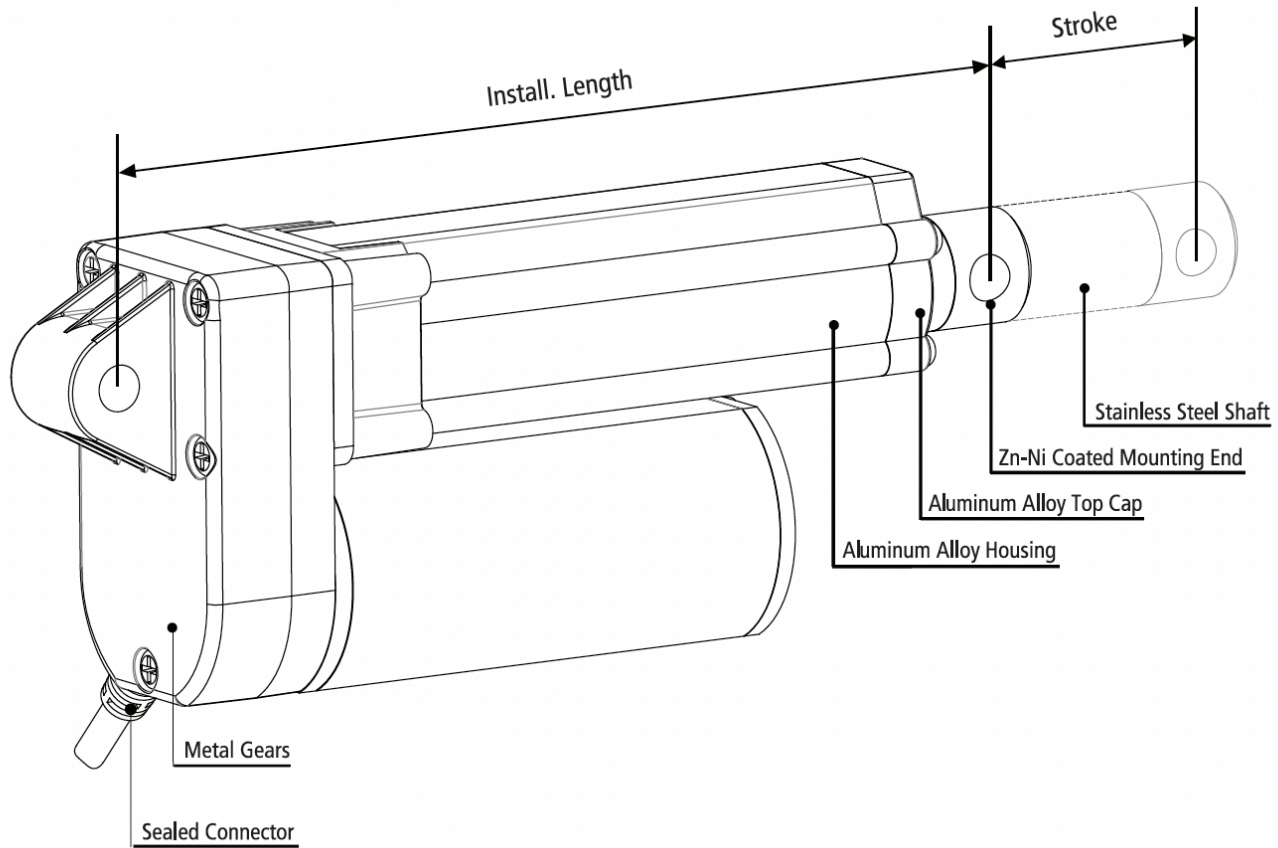

• Glossary of Terms



Stroke	How far the rod extends outwards from the body. The difference between fully extended length and fully retracted length. (Customizable)
Installation Length	The length of unit when fully closed. (Customizable)
Front Mounting End	Optional.
Rear Mounting End	Optional.
Mounting Holes	Can be rotated by 90°.
Dynamic Force	The max. force the actuator can carry while it is moving.
Self-locking	The max. force the actuator can hold when it is stopped.
Weather Protection	IPXX. The first digit: Dust Protection. The Second Digit: Liquids Protection. Please refer to [Table 1.]
Duty Cycle	Continuous working time "a", rest time "b". Duty Cycle is $a/(a+b) \times 100\%$. Please refer to [Table 1.]
Speed	Includes free-load speed and full load speed.
Hall Sensor	Provides pulse signals. Displacement measurement is achieved through pulse counting, and the phase difference of the waveform can be used to identify the rotation direction of motor. Check [Table 1] to see if it is available.
Potentiometer	Potentiometer is a three-terminal variable resistor with a rotating contact which is used to measure the displacement of actuators. Check [Table 1] to see if it is available.
Manual Override	Can be used to extend or retract the actuator when there is no power in an emergency situation. Check [Table 1] for availability.

• General Specifications

Color	<input checked="" type="checkbox"/> Silver	<input type="checkbox"/> Black	<input type="checkbox"/> Custom						
Lead Screw	<input checked="" type="checkbox"/> Acme Screw	<input type="checkbox"/> Ball Screw							
Operation Mode	<input checked="" type="checkbox"/> Electrical	<input type="checkbox"/> Electrical + Manual							
Application	<input checked="" type="checkbox"/> Industrial	<input type="checkbox"/> Furniture	<input type="checkbox"/> Medical						
Operational Temp.	<input type="checkbox"/> 5°C to 40°C	<input checked="" type="checkbox"/> -10°C to 65°C	<input checked="" type="checkbox"/> -40°C to 65°C						
Operating Noise	<input type="checkbox"/> ≤45dB	<input type="checkbox"/> ≤50dB	<input checked="" type="checkbox"/> ≤65dB						
Stroke Range	<input checked="" type="checkbox"/> 50 to 600mm	<input checked="" type="checkbox"/> 600 to 1,000mm							
Dynamic Load	<input type="checkbox"/> ≤1,200N	<input checked="" type="checkbox"/> ≤2,000N	<input type="checkbox"/> ≤4,000N				<input type="checkbox"/> ≤10,000N	<input type="checkbox"/> ≤12,000N	<input type="checkbox"/> ≤20,000N
Duty Cycle	<input type="checkbox"/> 10%	<input type="checkbox"/> 20%	<input checked="" type="checkbox"/> 25%*				<input type="checkbox"/> ≤50%	<input type="checkbox"/> 100%	
Motor Type	<input checked="" type="checkbox"/> Brushed DC	<input type="checkbox"/> Stepper Motor	<input type="checkbox"/> Brushless				<input type="checkbox"/> Servo Motor		
Overload Protection	<input checked="" type="checkbox"/> None	<input type="checkbox"/> Clutch	<input type="checkbox"/> Electronic	<input type="checkbox"/> Thermistor					
Weather Protection	<input type="checkbox"/> IP20	<input type="checkbox"/> IP43	<input type="checkbox"/> IP54	<input type="checkbox"/> IP65	<input checked="" type="checkbox"/> IP66	<input type="checkbox"/> IP69K			
Position Feedback	<input checked="" type="checkbox"/> None	<input checked="" type="checkbox"/> Endstop Signal	<input checked="" type="checkbox"/> Hall Sensor	<input checked="" type="checkbox"/> Potentiometer	<input type="checkbox"/> Encoder	<input checked="" type="checkbox"/> Reed Switches			
Input Voltage	<input checked="" type="checkbox"/> 12VDC	<input checked="" type="checkbox"/> 24VDC	<input checked="" type="checkbox"/> 36VDC	<input checked="" type="checkbox"/> 48VDC	<input type="checkbox"/> 110VAC	<input type="checkbox"/> 220VAC			

*Note: Do not exceed 4 minutes continuous working at full load at 20°C ambient temperature.

[Table 1]

Options for MLA-J

Available Other Models

• Technical Parameters

Code	Max. Dynamic Load (*See Note 2)	Max. Self-Locking Load	Reduction Ratio	Pitch	Speed +/-10% (mm/sec) (*See Note 1)		Max. Stroke No Pot. (*See Note 3)	Max. Stroke with Pot. (*See Note 3)
	(N)	(N)			Free Load	Full Load		
A	2,000	3,000	40:1	3.17	5	4	1,000	200
B	1,600	2,200	30:1	3.17	7	5.5	1,000	200
C	1,200	1,600	20:1	3.17	10	8	1,000	200
D	700	900	10:1	3.17	20	14	1,000	200
E	300	400	5:1	3.17	40	30	1,000	200
F	1,200	1,600	40:1	5	8	6	1,000	300
G	800	1,100	30:1	5	10.5	8	1,000	300
H	600	800	20:1	5	15	11	1,000	300
I	500	600	10:1	5	30	22	1,000	300
J	200	300	5:1	5	55	45	1,000	300

[Table 2]

*Notes:

- Measurements are made with actuators in connection with stable power supplies and ambient temperature of 20°C.
- For example, when real load is 1,200N, choosing code "C" is recommended. You can also choose "A", "B", or "F," each of which come with an increased load buffer, higher safety factors, and extended product service time.
- Many factors affect the "Customizable Maximum Stroke," such as load, speed, and direction of force. Actual application scenarios should be considered. Please contact cs@machmo.com if your required parameters are not listed.

• Performance

Current vs. Load

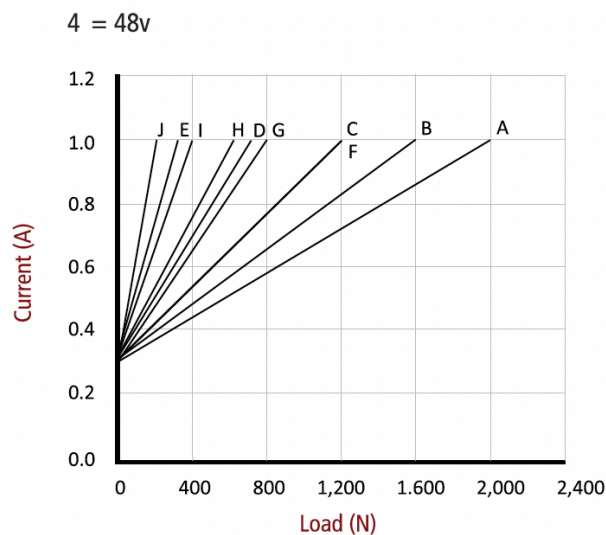
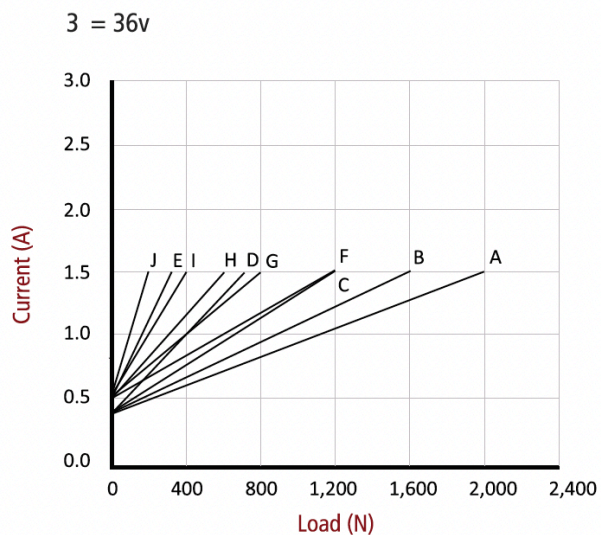
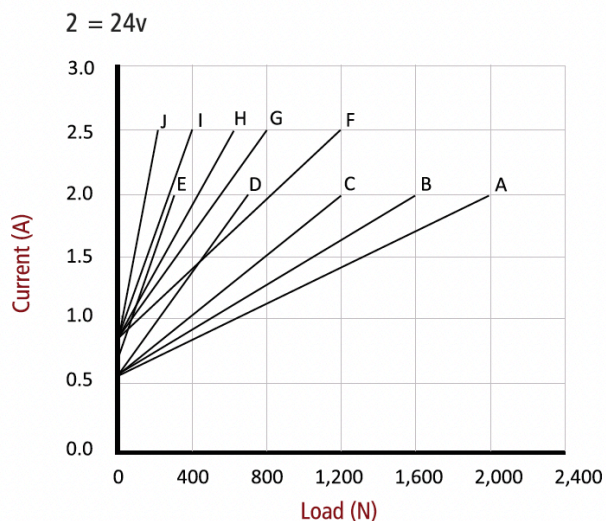
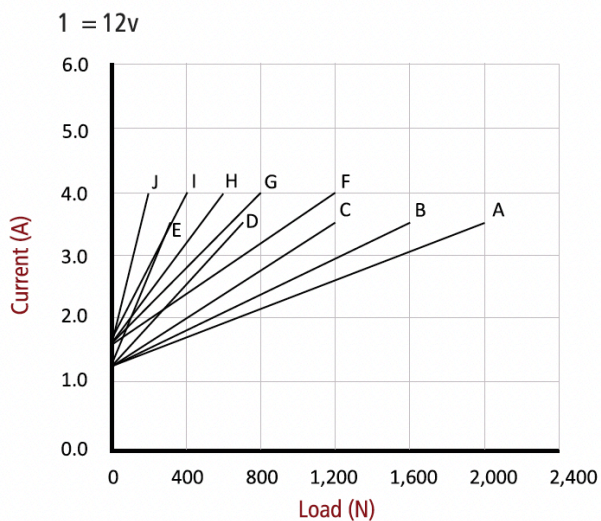

Speed vs. Load

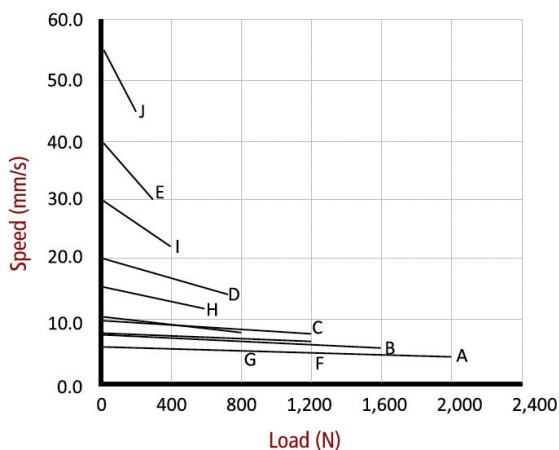

* Note: Measurements are made with Actuators in Connection with Stable Power Supplies and Ambient Temperature of 20°C.

•Front Mounting End

1. Please contact cs@machmo.com if none of the options below meet your requirements.

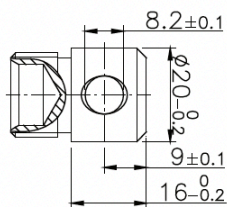

F01

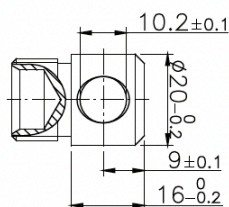

F02

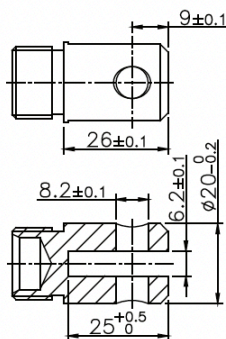

F03

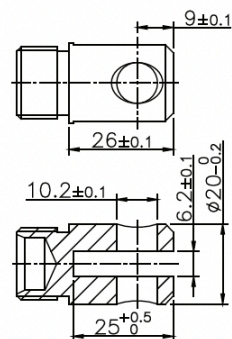

F04

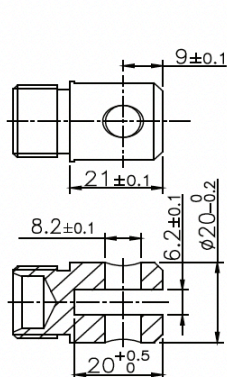

F05

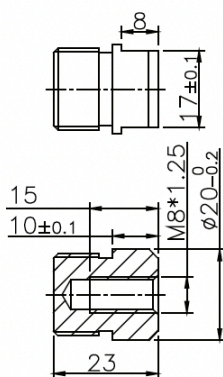

F06

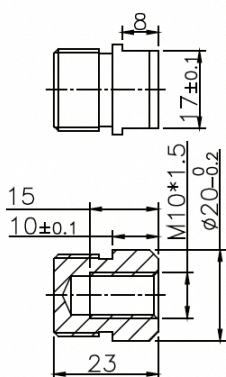

F07

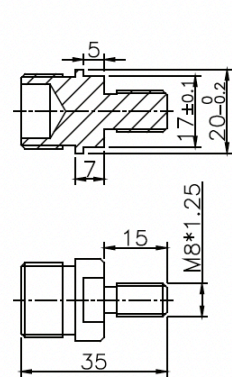

F08

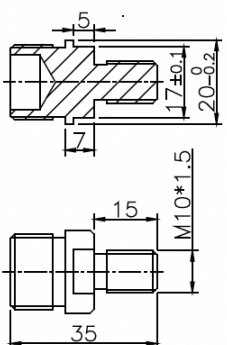

F09

2. Start of Installation Length

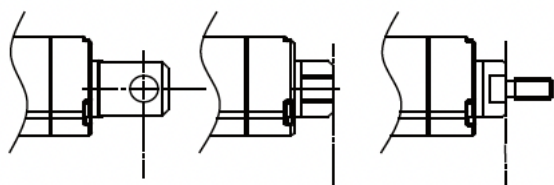

3. Hole Directions

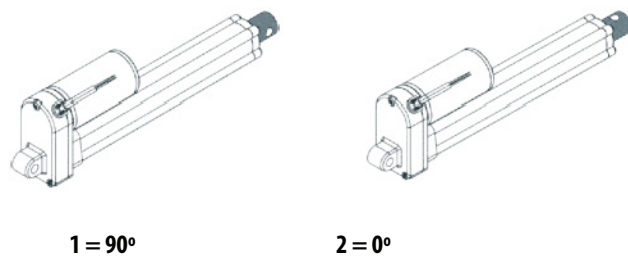

1 = 90°

2 = 0°

• Rear Mounting End

1. Please contact cs@machmo.com if none of the options below meet your requirements.

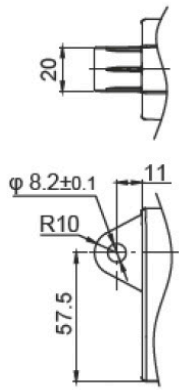

R01

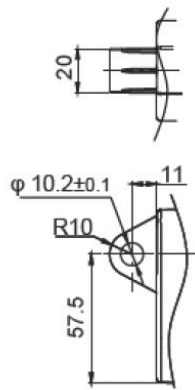

R02

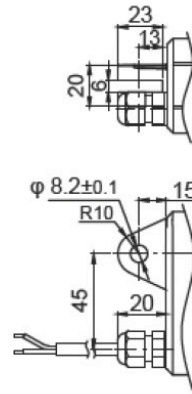

R03

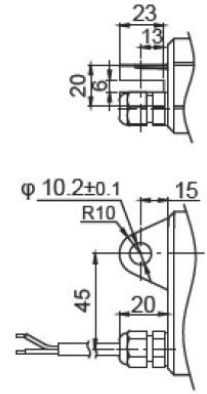

R04

2. End of Installation Length

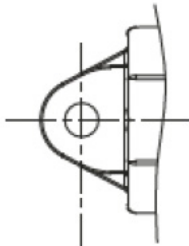

3. Hole Directions

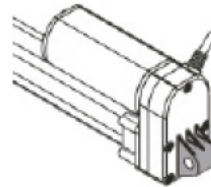

1 = 90°

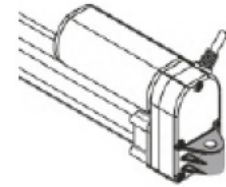

2 = 0°

*Not applied to R03 & R04

• Product Dimensions - No Potentiometer

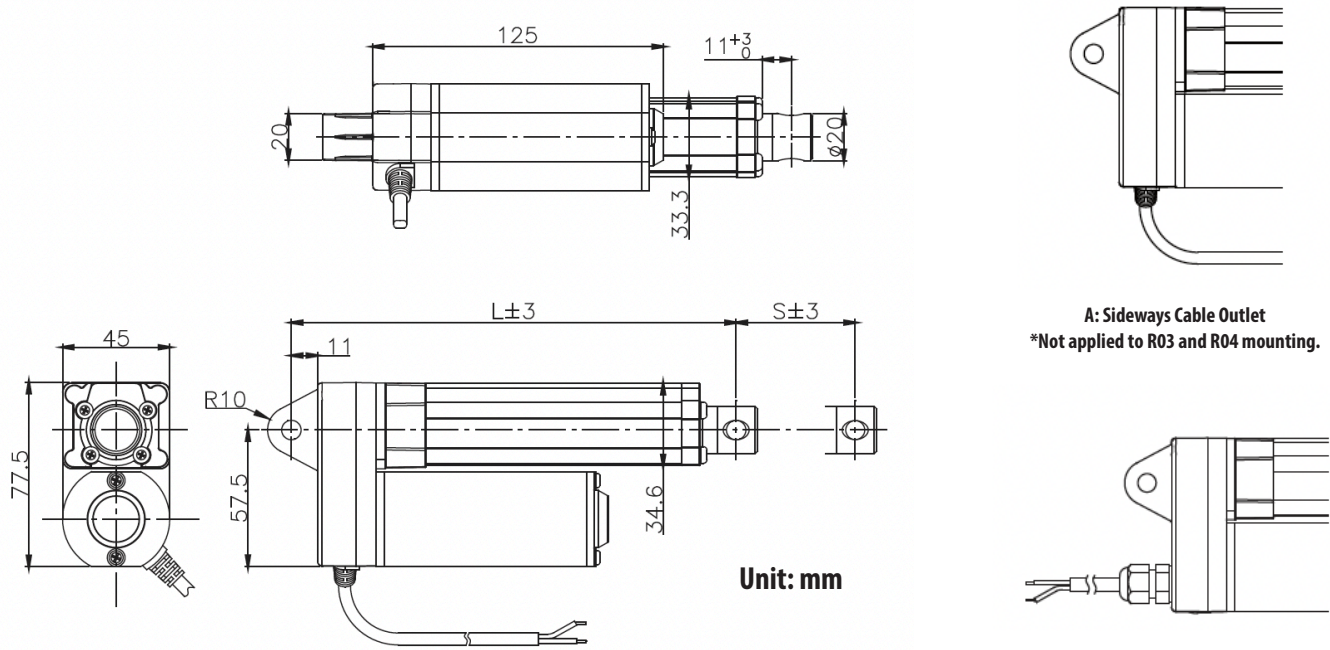

A. Mounting Ends VS. Installation Length

Front Mounting Ends	Rear Mounting Ends	
	R01, R02	R03, R04
F01, F02, F05-F09	$A \geq S+108\text{mm}$	$A \geq S+112\text{mm}$
F03, F04	$A \geq S+155\text{mm}$	$A \geq S+119\text{mm}$

[Table 3]

B. Stroke VS. Installation Length

Stroke (S) (mm)	Installation Length (L) (mm)
30 - 299	+ 0
300 - 399	+ 12
≥ 400	+ 22

[Table 4]

C. Reed Switch

Reed Switch	Installation Length (L) (mm)
Optional	+ 10

[Table 5]

How to Calculate "Installation Length": Example:

$S = \text{Stroke}$, $L = \text{Installation Length}$
 $L \geq A + B + C$

Front Mount	Rear Mount	S (mm)	A (mm)	B (mm)	C (mm)	$L \geq A + B + C$ (mm)
F04	R01	300	$300 + 115$	+12	$C = 0$	≥ 427

[Table 6]

• Product Dimensions - With Potentiometer

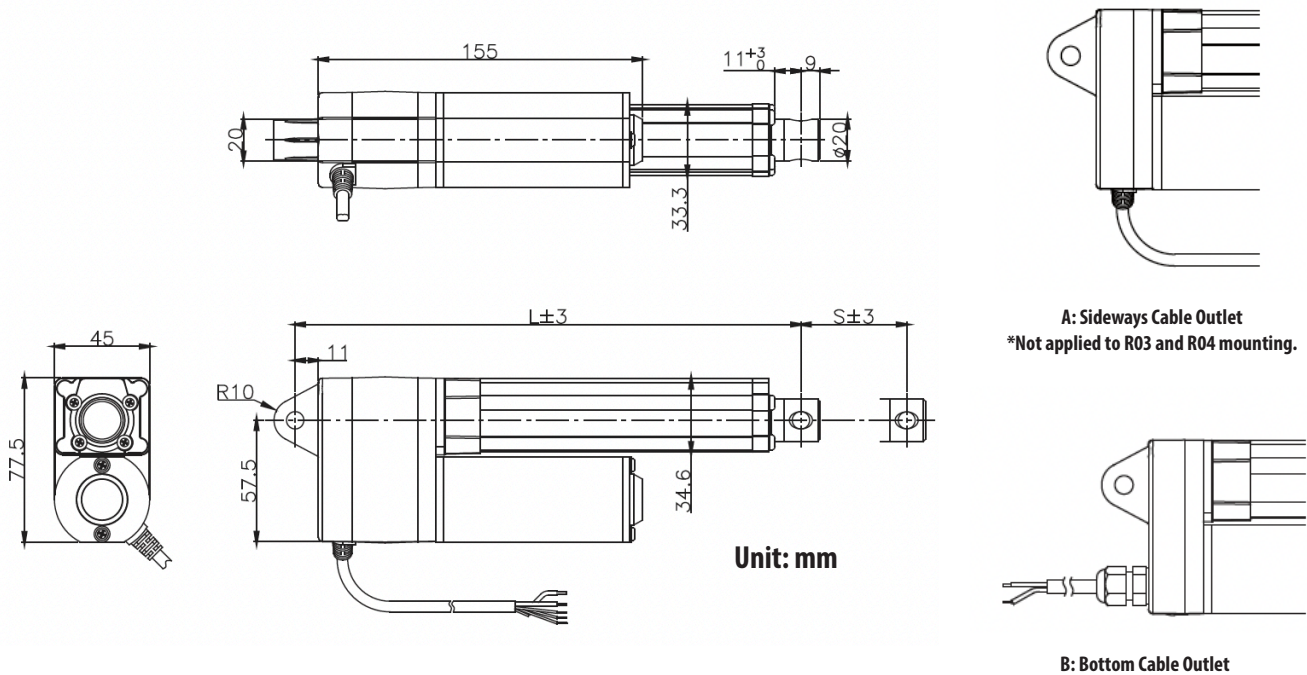

A. Mounting Ends VS. Installation Length

Front Mounting Ends	Rear Mounting Ends	
	R01, R02	R03, R04
F01, F02, F05-F09	$A \geq S+140\text{mm}$	$A \geq S+144\text{mm}$
F03, F04	$A \geq S+147\text{mm}$	$A \geq S+151\text{mm}$

[Table 7]

B. Stroke VS. Installation Length

Stroke (S) (mm)	Installation Length (L) (mm)
30 - 300	+ 0

[Table 8]

C. Reed Switch

Reed Switch	Installation Length (L) (mm)
Optional	+ 10

[Table 9]

How to Calculate "Installation Length": Example:

$S = \text{Stroke}$, $L = \text{Installation Length}$
 $L \geq A + B + C$

Front Mount	Rear Mount	S (mm)	A (mm)	B (mm)	C (mm)	$L \geq A + B + C$ (mm)
F04	R01	300	$300 + 147$	+12	$C = 0$	≥ 447

[Table 10]

• Signal Feedback

0. Standard Limit Switches Without Signal Feedback

Standard MLA-J comes with limit switches that automatically shut off motor at the end of travel path.

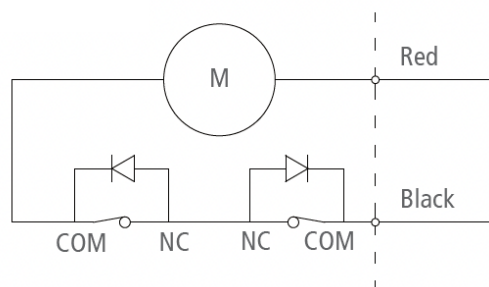

Wire Type		
	Black	Red
Extend	-	+
Retract	+	-

[Table 11]

1. Endstop Signal

The actuator can be equipped with endstop signal output, but it will not auto-stop at either end of travel.

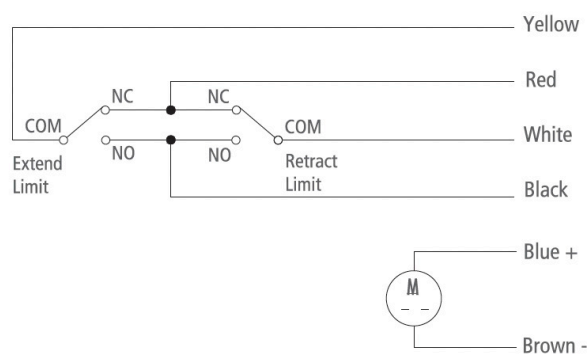

Wire Type		
	Brown	Blue
Extend	-	+
Retract	+	-
Signal Wire Coding		
Black	Extend or Retract Limit, N.O.	
Red	Extend or Retract Limit, N.C.	
Yellow	Extend Limit, COM.	
White	Retract Limit, COM.	

[Table 12]

2. Potentiometer

Starting Value 0KΩ

Code	Maximum Stroke	Resistance Value per mm
A, B, C, D, E	200mm	0.047KΩ
F, G, H, I, J	300mm	0.030KΩ

[Table 13]

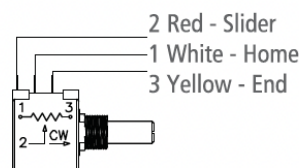

Connect 1+2, resistance value increase, actuator extend.

Signal Wiring Diagram

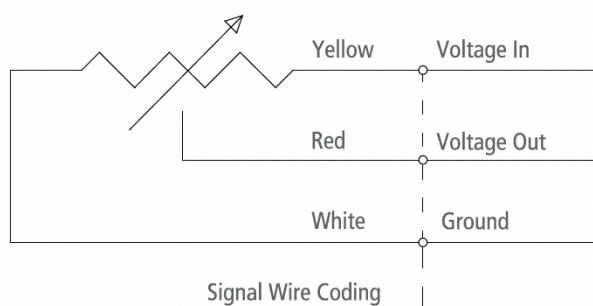

Internal Motor Wiring Diagram

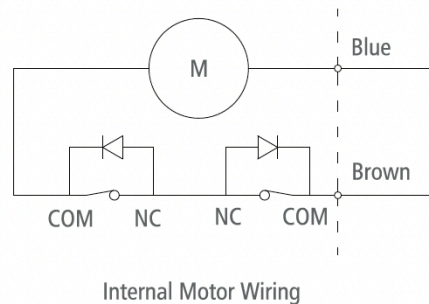

• Signal Feedback

3. Hall Effect Sensor (Standard Dual-sensor)

Code	Pulse Equivalent per Sensor (pulse/mm)	
	1 Pole Pair	4 Pole Pairs (Standard)
A	12.60	50.40
B	9.45	37.80
C	6.30	25.20
D	3.15	12.60
E	1.57	6.30
F	8.00	32.00
G	6.00	24.00
H	4.00	16.00
I	2.00	8.00
J	1.00	4.00

[Table 14]

Wire Coding

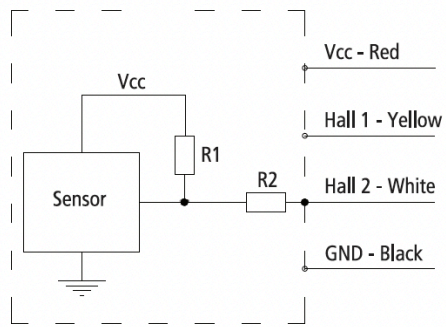

* Power supply (V)= 5~15V

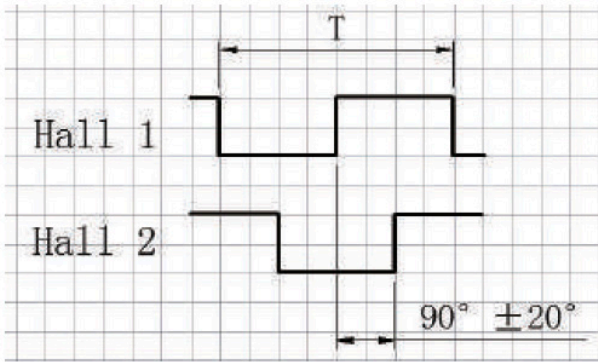

Oscillogram

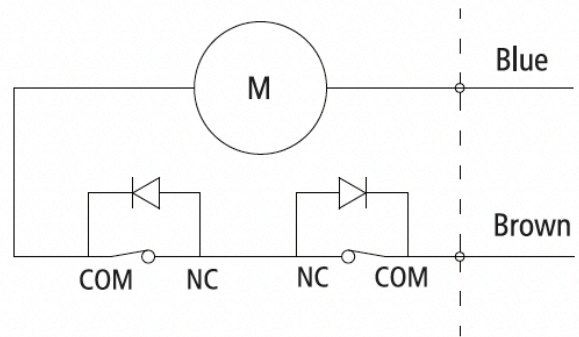

Internal Motor Wiring

4. Reed Switch

Standard N.O. Contact. Optional N.C. Contact.

• Product Inquiry Table

Selection	Specification	Available Options			
<input type="text"/>	Voltage	1 = 12V	2 = 24V	3 = 36V	4 = 48V
<input type="text"/>	Load and Speed	See Page 4			
<input type="text"/>	Stroke (mm)	Please contact cs@machmo.com if required stroke is out of range.			
<input type="text"/>	Installation Length (mm)	See [Tables 3-9]			
<input type="text"/>	Front Mounting End	F01 - F09		or FX = Custom	
<input type="text"/>	Rear Mounting End	R01 - R04		or RX = Custom	
<input type="text"/>	Mounting Hole Direction	Front 1 = 90°	Front 2 = 0°	Rear 1 = 90°	Rear 2 = 0°
<input type="text"/>	Signal Feedback	0 = None	1 = Endstop Signal	2 = Potentiometer	3 = Hall Signal
<input type="text"/>		4 = Reed Switches			
<input type="text"/>	Cable Length	1 = 500mm	2 = 1,000mm	3 = 2,000mm	X = Custom
<input type="text"/>	Connector	A = Sideways Cable Outlet		B = Bottom Cable Outlet	
<input type="text"/>		0 = Tinned Bare Wires	1 = Go with KZ Control	X = Custom	
<input type="text"/>	Working Temperature	1 = -10°C ~ 65°C		2 = -40°C ~ 65°C	
<input type="text"/>	Working Frequency	Estimated Work Cycles Per Day			
<input type="text"/>	End Use	Indoor or Outdoor?			

Application