

MLA-G2 Industrial Linear Actuator

2026 Catalog

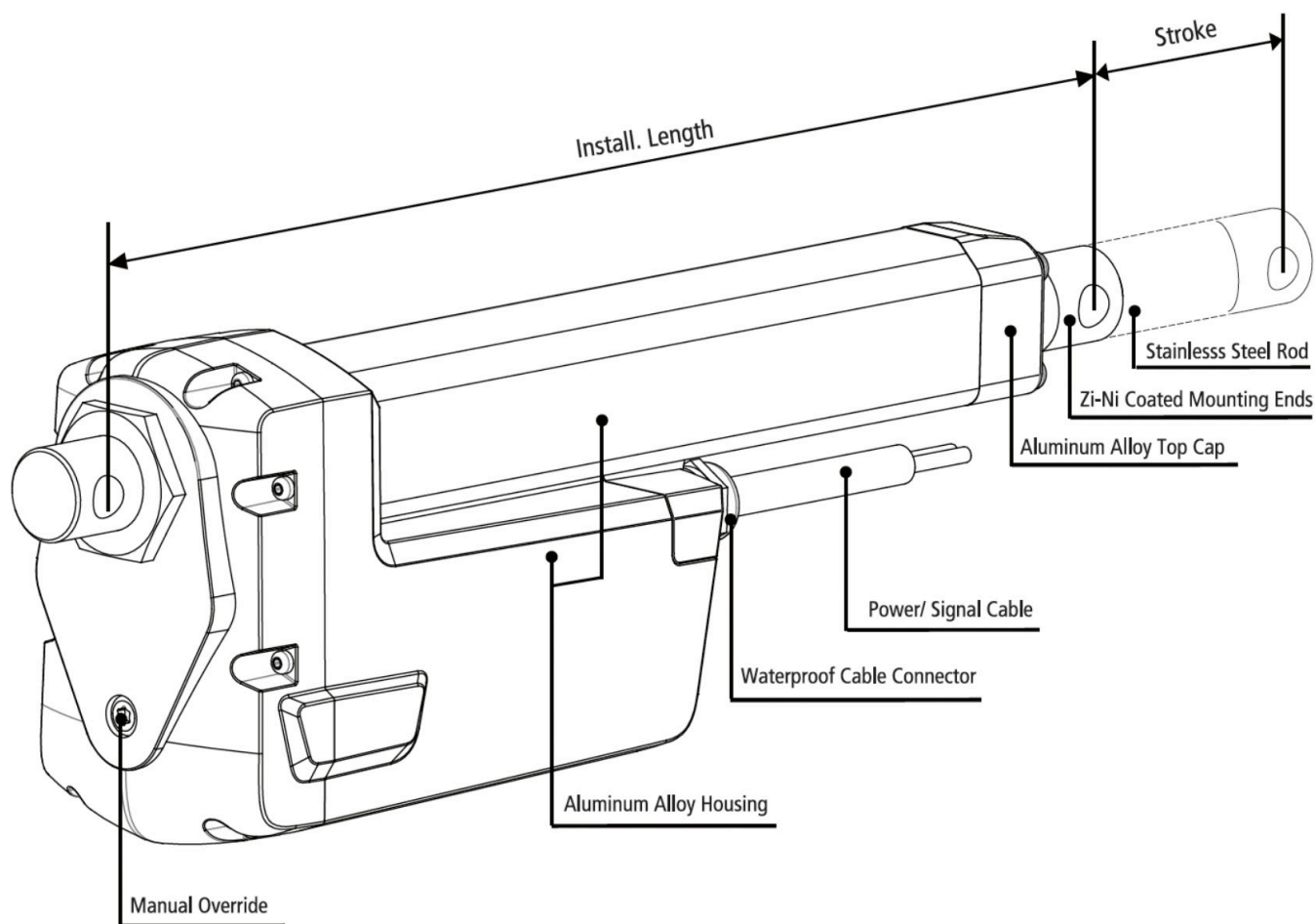

• Glossary of Terms



Stroke	How far the rod extends outwards from the body. The difference between fully extended length and fully retracted length. (Customizable)
Installation Length	The length of unit when fully closed. (Customizable)
Front Mounting End	Optional.
Rear Mounting End	Optional.
Mounting Holes	Can be rotated by 90°.
Dynamic Force	The max. force the actuator can carry while it is moving.
Self-locking	The max. force the actuator can hold when it is stopped.
Weather Protection	IPXX. The first digit: Dust Protection. The Second Digit: Liquids Protection. Please refer to [Table 1.]
Duty Cycle	Continuous working time "a", rest time "b". Duty Cycle is $a/(a+b) \times 100\%$. Please refer to [Table 1.]
Speed	Includes free-load speed and full load speed.
Hall Sensor	Provides pulse signals. Displacement measurement is achieved through pulse counting, and the phase difference of the waveform can be used to identify the rotation direction of motor. Check [Table 1] to see if it is available.
Potentiometer	Potentiometer is a three-terminal variable resistor with a rotating contact which is used to measure the displacement of actuators. Check [Table 1] to see if it is available.
Manual Override	Can be used to extend or retract the actuator when there is no power in an emergency situation. Check [Table 1] for availability.

• General Specifications

Color	<input checked="" type="checkbox"/> Silver	<input type="checkbox"/> Black	<input type="checkbox"/> Custom						
Lead Screw	<input checked="" type="checkbox"/> Acme Screw	<input checked="" type="checkbox"/> Ball Screw							
Operation Mode	<input type="checkbox"/> Electrical	<input checked="" type="checkbox"/> Electrical + Manual							
Application	<input checked="" type="checkbox"/> Industrial	<input type="checkbox"/> Furniture	<input type="checkbox"/> Medical						
Operational Temp.	<input type="checkbox"/> 5°C to 40°C	<input type="checkbox"/> -10°C to 65°C	<input checked="" type="checkbox"/> -40°C to 65°C						
Operating Noise	<input type="checkbox"/> ≤45dB	<input type="checkbox"/> ≤50dB	<input checked="" type="checkbox"/> ≤65dB						
Stroke Range	<input checked="" type="checkbox"/> 50 to 600mm	<input checked="" type="checkbox"/> 600 to 1,000mm							
Dynamic Load	<input type="checkbox"/> ≤1,200N	<input type="checkbox"/> ≤2,000N	<input type="checkbox"/> ≤4,000N				<input type="checkbox"/> ≤10,000N	<input checked="" type="checkbox"/> ≤12,000N	<input type="checkbox"/> ≤20,000N
Duty Cycle	<input type="checkbox"/> 10%	<input type="checkbox"/> 20%	<input checked="" type="checkbox"/> 25%*				<input type="checkbox"/> ≤50%	<input type="checkbox"/> 100%	
Motor Type	<input checked="" type="checkbox"/> Brushed DC	<input type="checkbox"/> Stepper Motor	<input type="checkbox"/> Brushless				<input type="checkbox"/> Servo Motor		
Overload Protection	<input type="checkbox"/> None	<input type="checkbox"/> Clutch	<input checked="" type="checkbox"/> Electronic	<input type="checkbox"/> Thermistor					
Weather Protection	<input type="checkbox"/> IP20	<input type="checkbox"/> IP43	<input type="checkbox"/> IP54	<input type="checkbox"/> IP65	<input checked="" type="checkbox"/> IP66	<input type="checkbox"/> IP69K			
Position Feedback	<input checked="" type="checkbox"/> None	<input type="checkbox"/> Endstop Signal	<input checked="" type="checkbox"/> Hall Sensor	<input checked="" type="checkbox"/> Potentiometer	<input type="checkbox"/> Encoder	<input checked="" type="checkbox"/> Reed Switches			
Input Voltage	<input checked="" type="checkbox"/> 12VDC	<input checked="" type="checkbox"/> 24VDC	<input checked="" type="checkbox"/> 36VDC	<input checked="" type="checkbox"/> 48VDC	<input type="checkbox"/> 110VAC	<input type="checkbox"/> 220VAC			

*Note: Do not exceed 4 minutes continuous working at full load at 20°C ambient temperature.

[Table 1]

Options for MLA-G2 Available Other Models

• Technical Parameters

Code	Max. Dynamic Load (*See Note 2)	Max. Self-Locking Load	Reduction Ratio	Pitch (mm)	Speed +/-10% (mm/sec) (*See Note 1)		Max. Stroke No Pot. (*See Note 3) (mm)	Max. Stroke with Pot. (*See Note 3) (mm)
	(N)	(N)			Free Load	Full Load		
A	12,000	15,000	43:1	4.0	6.0	4.0	1,000	176
B	11,000	12,000	31:1	4.0	8.0	5.2	1,000	176
C	7,500	9,000	21:1	4.0	12.0	8.0	1,000	176
D	10,000	12,000	43:1	8.0	12.0	7.0	1,000	352
E	7,000	8,000	31:1	8.0	17.0	9.5	1,000	352
F	5,000	6,000	21:1	8.0	25.0	14.0	1,000	352
G	6,500	8,000	43:1	12.0	18.5	11.0	1,000	528
H	4,500	5,500	31:1	12.0	25.0	13.0	1,000	528
I	3,200	4,000	21:1	12.0	37.0	23.0	1,000	528

[Table 2]

*Notes:

1. Measurements are made with actuators in connection with stable power supplies and ambient temperature of 20°C.
2. For example, when real load is 10,000N, choosing code "D" is recommended. You can also choose "A" or "B," each of which come with an increased load buffer, higher safety factors, and extended product service time.
3. Many factors affect the "Customizable Maximum Stroke," such as load, speed, and direction of force. Actual application scenarios should be considered. Please contact cs@machmo.com if your required parameters are not listed.

• Performance

Current vs. Load

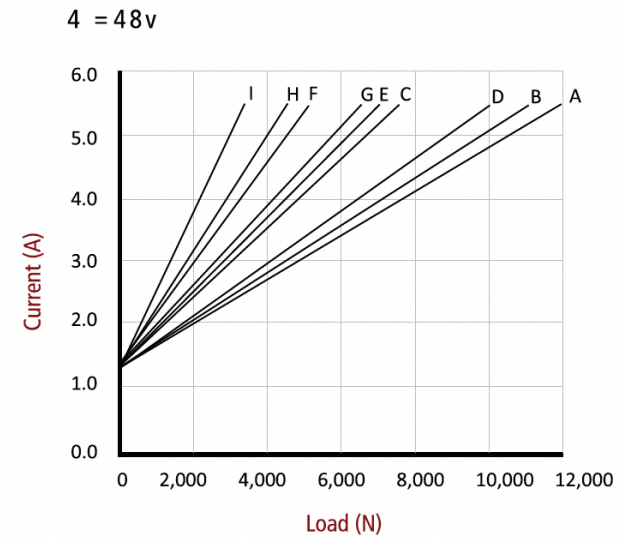
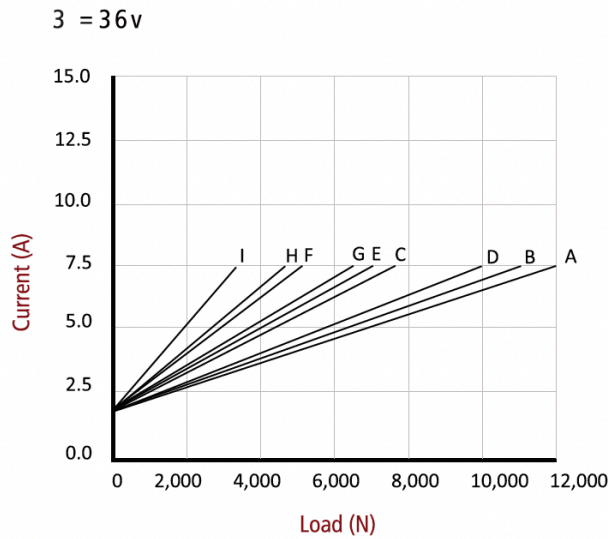
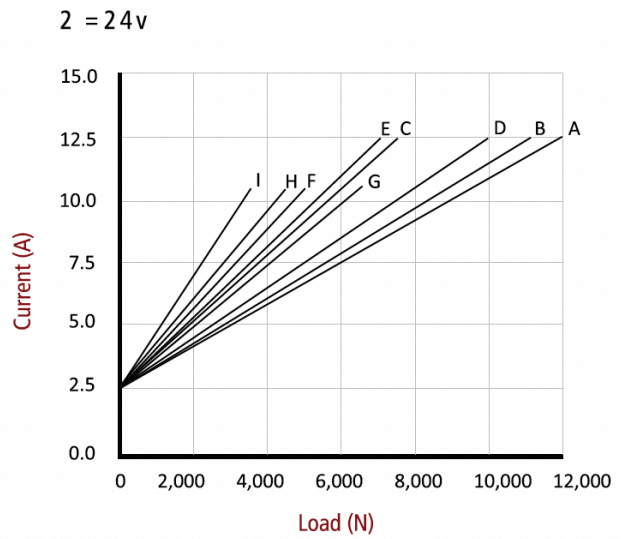
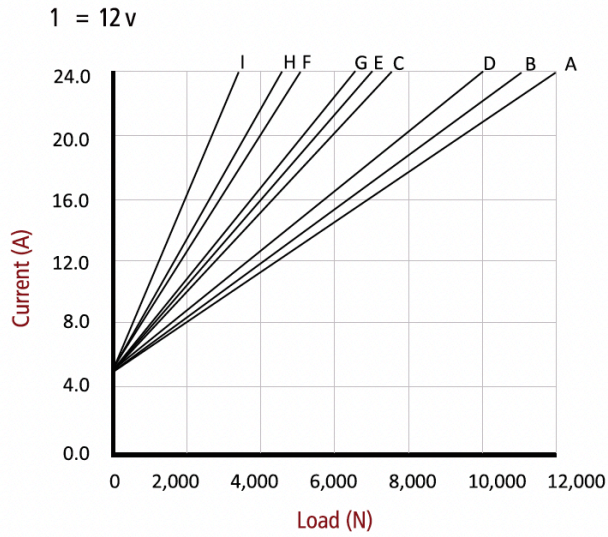

Speed vs. Load

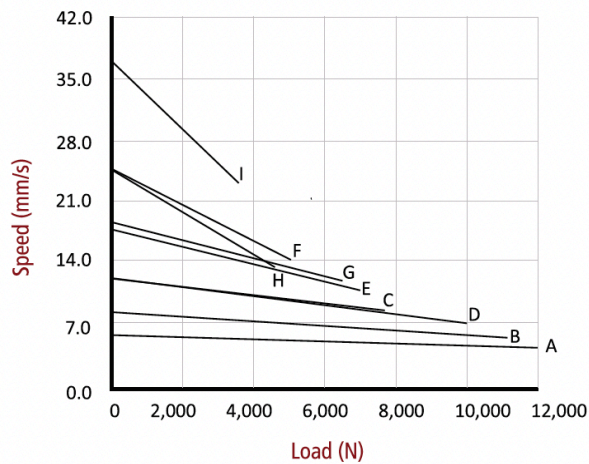

* Note: Measurements are made with Actuators in Connection with Stable Power Supplies and Ambient Temperature of 20°C.

•Front Mounting End

1. Please contact cs@machmo.com if none of the options below meet your requirements.

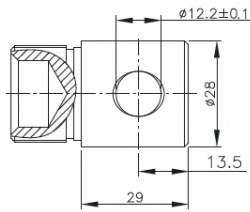

F01

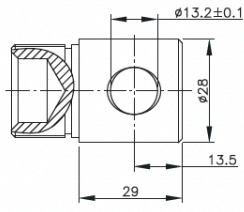

F02

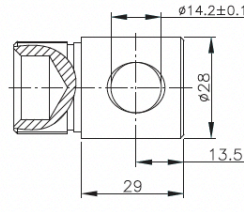

F03

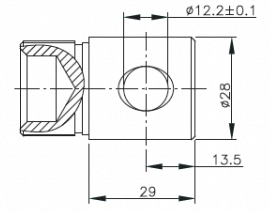

F04

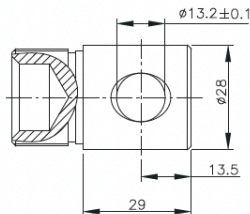

F05

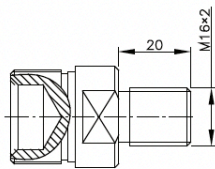

F06

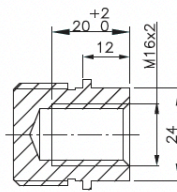

F07

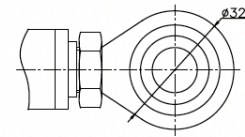

F08

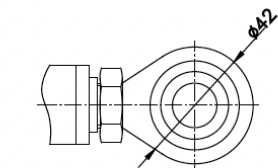
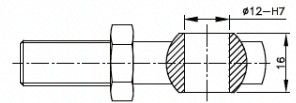
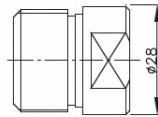
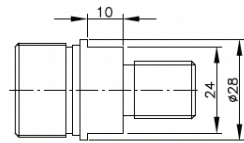
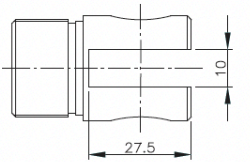

F09

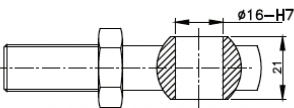

2. Start of Installation Length

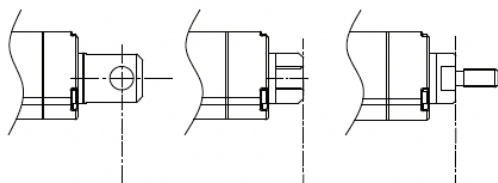

3. Hole Directions

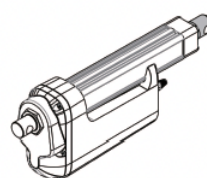

1 = 90°

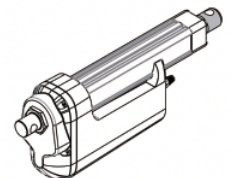

2 = 0°

• Rear Mounting End

1. Please contact cs@machmo.com if none of the options below meet your requirements.

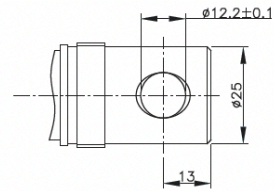

R01

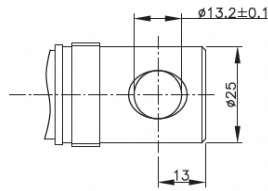

R02

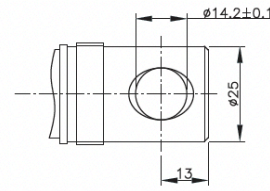

R03

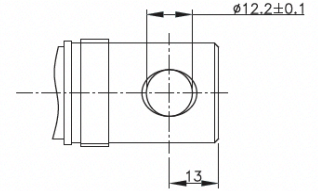

R04

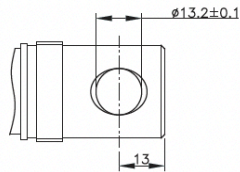
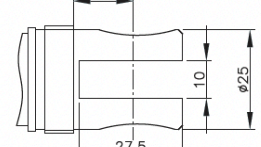
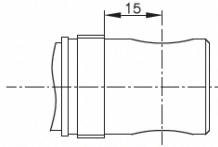
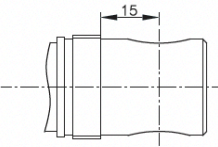
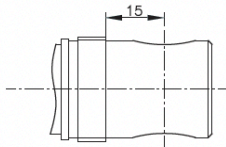

R05

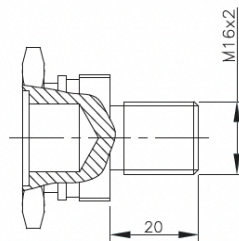
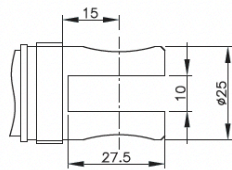

R06

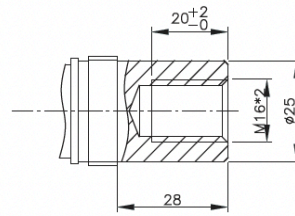

R07

2. End of Installation Length

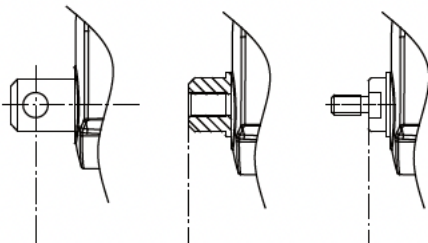

3. Hole Directions

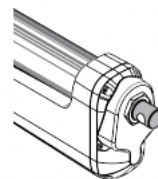

1 = 90°

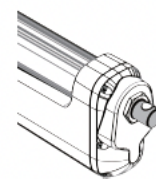

2 = 0°

• Product Dimensions

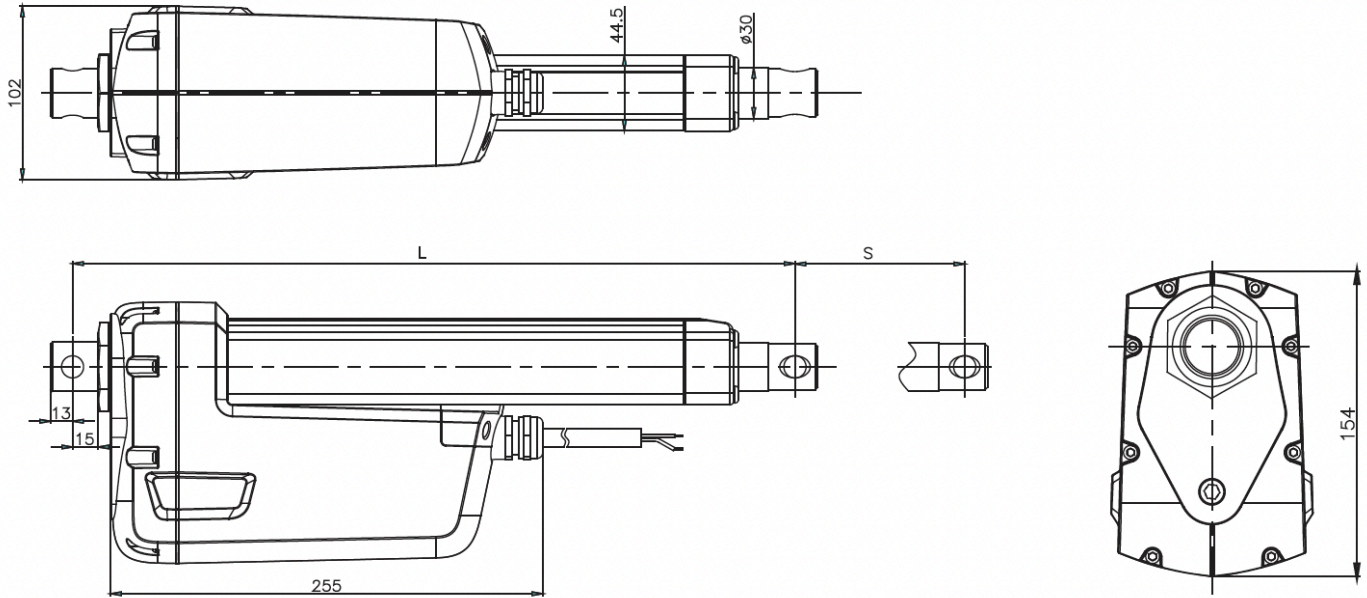

A. Mounting Ends VS. Installation Length

	Rear Mounting Ends
Front Mounting Ends	R01, R02, R03, R04, R05, R06, R07
F01, F02, F03, F04, F05, F06, F07	$A \geq S + 200\text{mm}$ (315mm min.)
F08, F09	$A \geq S + 250\text{mm}$ (340mm min.)

[Table 3]

B. Stroke VS. Installation Length

Stroke (S) (mm)	Installation Length (L) (mm)
50 - 299	+ 0
300 - 599	+ 50
≥ 600	+ 100

Unit: mm

[Table 4]

How to Calculate "Installation Length":

$S = \text{Stroke}, L = \text{Installation Length}$
 $L \geq A + B$

Example:

Front Mount	Rear Mount	S (mm)	A (mm)	B (mm)	$L \geq A + B$ (mm)
F08	R01	300	340	+0	≥ 340

[Table 5]

• Signal Feedback

1.Hall Effect Sensor

Option A (Standard)

Dual-sensor, Monitor Gearbox

Code	Gear Ratio		Pitch	Equivalent (pulse/mm)	
	Actuator	Sensor		1 Pole Pair	4 Pole Pairs (Standard)
A	43.404:1	16:58	4	0.906	3.625
B	31.131:1	20:54		0.675	2.700
C	20.843:1	27:47		0.435	1.741
D	43.404:1	16:58	8	0.453	1.813
E	31.131:1	20:54		0.338	1.350
F	20.843:1	27:47		0.218	0.870
G	43.404:1	16:58	12	0.302	1.209
H	31.131:1	20:54		0.225	0.900
I	20.843:1	27:47		0.145	0.580

[Table 6]

Option B

Dual-sensor, Monitor Motor Rotation

Code	Gear Ratio		Pitch	Equivalent (pulse/mm)	
	Actuator	Sensor		1 Pole Pair	4 Pole Pairs (Standard)
A	43.404:1		4	10.851	43.404
B	31.131:1			7.783	31.131
C	20.843:1			5.211	20.843
D	43.404:1		8	5.426	21.702
E	31.131:1			3.891	15.566
F	20.843:1			2.605	10.422
G	43.404:1		12	3.617	14.468
H	31.131:1			2.594	10.377
I	20.843:1			1.737	6.948

[Table 7]

Option A (Standard)

Dual-sensor, Monitor Gearbox

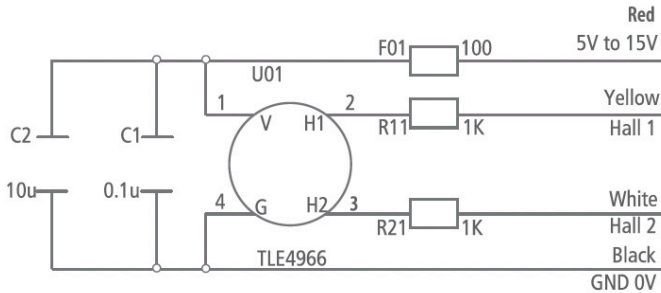

Option B

Dual-sensor, Monitor Motor Rotation

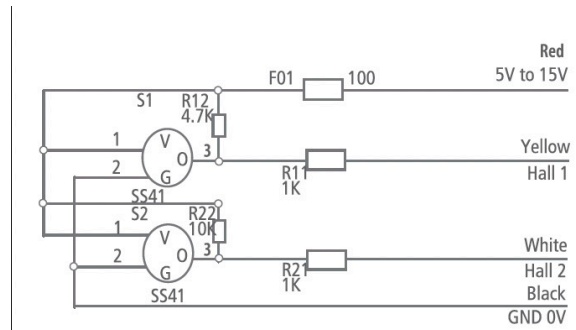

Option A (Standard)

Dual-sensor, Monitor Gearbox

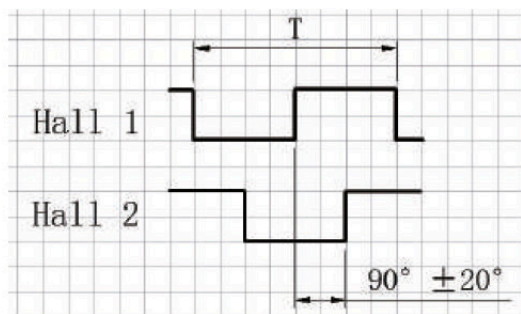

Oscillogram with Two Sensors

Option B

Dual-sensor, Monitor Motor Rotation

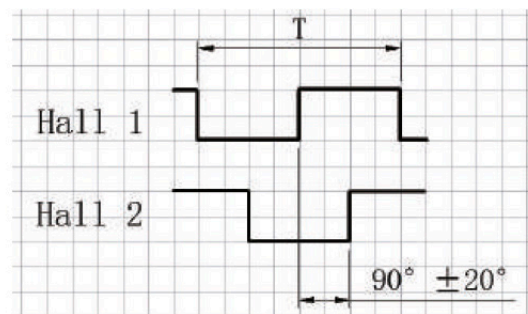

Oscillogram with Two Sensors

• Signal Feedback

2. Potentiometer

Signal Wires

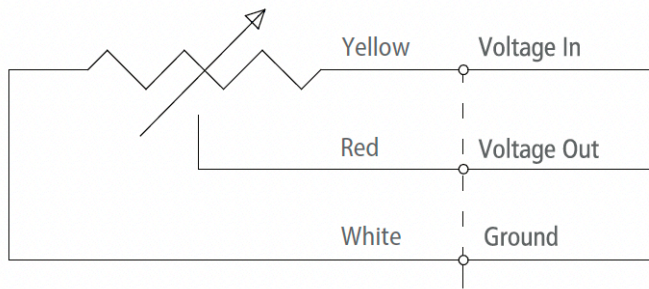

Internal Motor Wiring

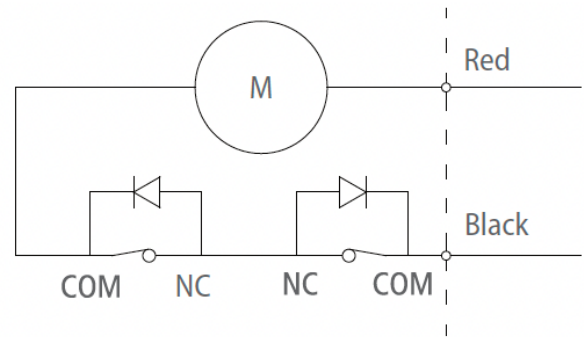

Starting Value 0.2 ~0.4KΩ

Code	Maximum Stroke	Resistance Value per mm
A, C, E	176mm	0.0568KΩ
B, D, F	352mm	0.0284KΩ
G, H, I	528mm	0.0189KΩ

[Table 8]

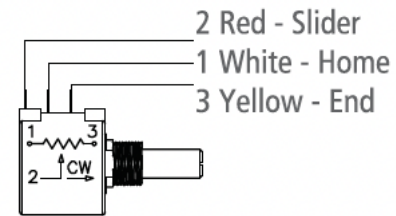

Connect 1+2, resistance value increase, actuator extend.

3. Reed Switch

Standard N.O. Contact. Optional N.C. Contact.

• Control and Connector

1 = Logic level control

2 = Go with SK523 control

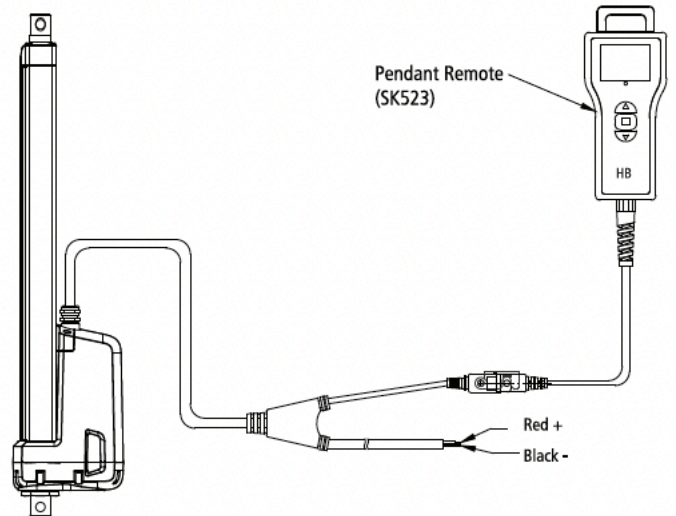
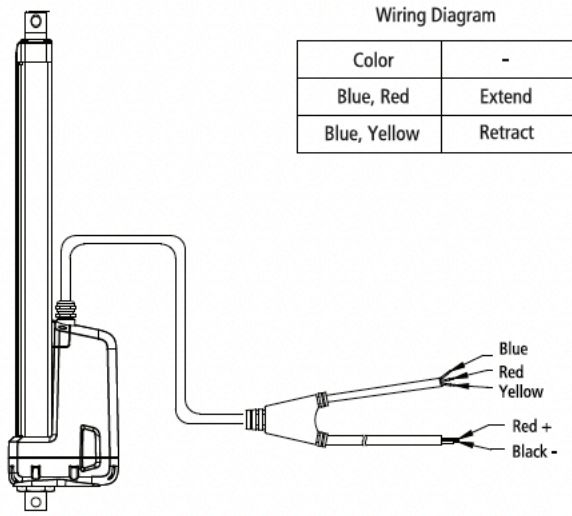

S = Synchronized control (2-4 actuators)

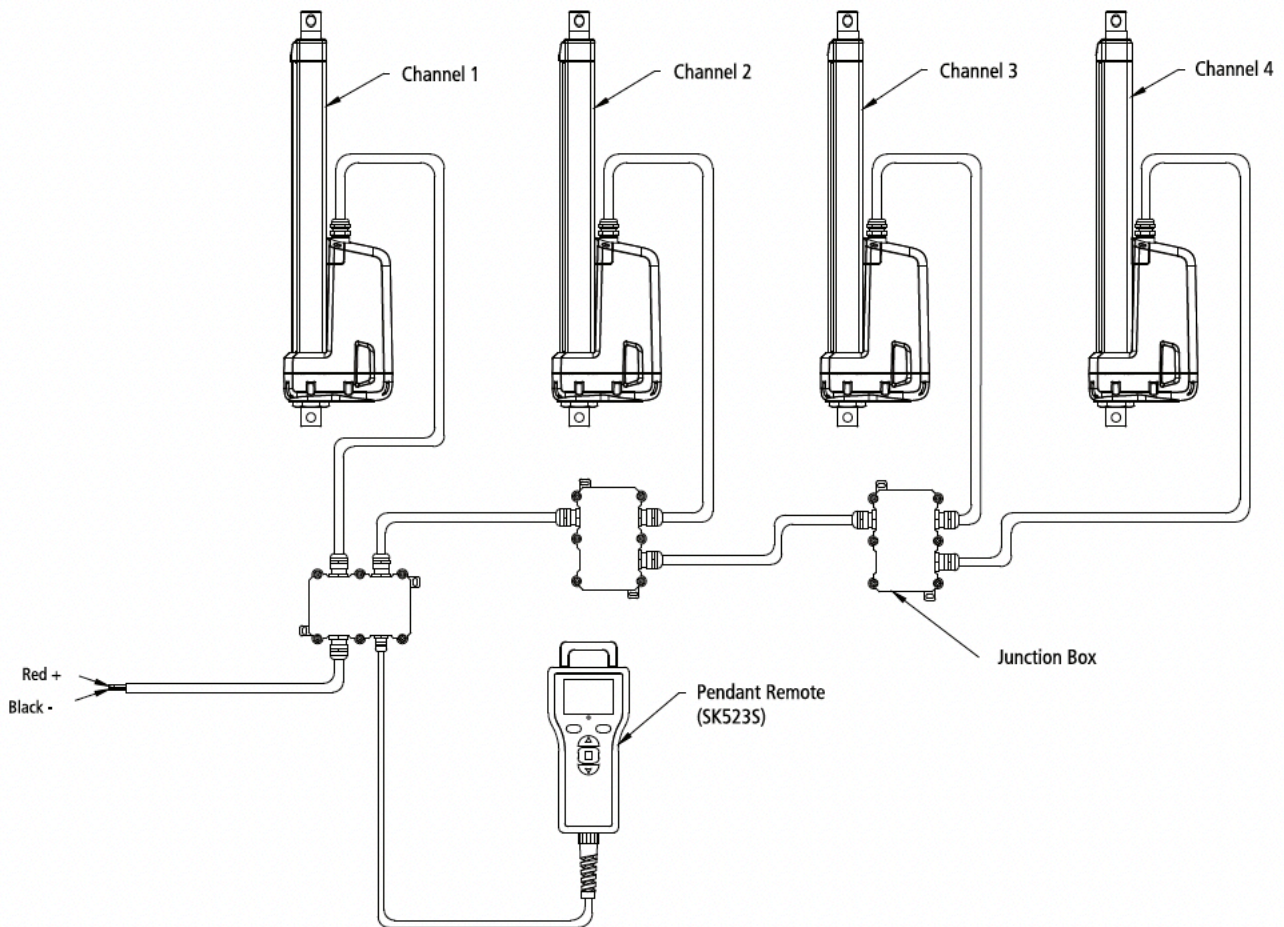

• Product Inquiry Table

Selection	Specification	Available Options			
<input type="text"/>	Voltage	1 = 12V	2 = 24V	3 = 36V	4 = 48V
<input type="text"/>	Load and Speed	See [Table 2]			
<input type="text"/>	Stroke (mm)	Please contact cs@machmo.com if required stroke is out of range.			
<input type="text"/>	Installation Length (mm)	See [Tables 3 & 4]			
<input type="text"/>	Front Mounting End	F01 - F09		or FX = Custom	
<input type="text"/>	Rear Mounting End	R01 - R07		or RX = Custom	
<input type="text"/>	Mounting Hole Direction	Front 1 = 90°	Front 2 = 0°	Rear 1 = 90°	Rear 2 = 0°
<input type="text"/>	Signal Feedback	0 = None	1 = Hall Sensor	2 = Potentiometer	3 = Reed Switches
<input type="text"/>	Cable Length	1 = 400mm	2 = 1,000mm	3 = 2000mm	X = Custom
<input type="text"/>	Connector	0 = Tinned Bare Wires	1 = Logic Level Control	2 = Go with SK Control	3 = Synchronized Control
<input type="text"/>		X = Custom			
<input type="text"/>	Working Temperature	1 = -40°C ~ 65°C			
<input type="text"/>	Working Frequency	Estimated Work Cycles Per Day			
<input type="text"/>	End Use	Indoor or Outdoor?			

Application