

# MLA-B6 Industrial Linear Actuator

---

2026 Catalog



• Product Overview

MLA-B6 Linear Actuators are a versatile, environmentally friendly motion control solution for a wide range of industrial applications. Featuring a corrosion-resistant aluminum alloy inner tube and outer casing, the MLA-B6 actuator’s 24VDC brushed motor offers a load thrust up to 6,000N and can pull up to 4,000N.

Features including built-in Electrical Limit Switches, high-strength front and back mounting fixtures, average noise level of ≤48dB, and an optional “Push Only/No Pull” function make this actuator a great choice for industries requiring strong performance with environmental adaptability.

Compatible Control Boxes:

- MLA-CB8
- MLA-CB13A
- MLA-CB-T
- MLA-CB13B

• General Specifications

Color	<input checked="" type="checkbox"/> Silver	<input checked="" type="checkbox"/> Black	<input type="checkbox"/> Custom						
Lead Screw	<input checked="" type="checkbox"/> Acme Screw	<input type="checkbox"/> Ball Screw							
Operation Mode	<input checked="" type="checkbox"/> Electrical	<input type="checkbox"/> Electrical + Manual							
Application	<input checked="" type="checkbox"/> Industrial	<input type="checkbox"/> Furniture	<input type="checkbox"/> Medical						
Operational Temp.	<input checked="" type="checkbox"/> 5°C to 40°C	<input type="checkbox"/> -10°C to 65°C	<input type="checkbox"/> -40°C to 85°C						
Stroke Range	<input checked="" type="checkbox"/> 50 to 650mm	<input type="checkbox"/> 650 to 1,000mm							
Dynamic Load	<input type="checkbox"/> ≤1,200N	<input type="checkbox"/> ≤2,000N	<input type="checkbox"/> ≤4,000N				<input checked="" type="checkbox"/> ≤6,000N	<input type="checkbox"/> ≤12,000N	<input type="checkbox"/> ≤20,000N
Duty Cycle	<input checked="" type="checkbox"/> 10%*	<input type="checkbox"/> 20%	25%				<input type="checkbox"/> ≤50%	<input type="checkbox"/> 100%	
Motor Type	<input checked="" type="checkbox"/> Brushed DC	<input type="checkbox"/> Stepper Motor	<input type="checkbox"/> Brushless				<input type="checkbox"/> Servo Motor		
Overload Protection	<input type="checkbox"/> None	<input type="checkbox"/> Clutch	<input checked="" type="checkbox"/> Electronic				<input type="checkbox"/> Thermistor		
Weather Protection	<input type="checkbox"/> IP20	<input type="checkbox"/> IP43	<input type="checkbox"/> IP54	<input type="checkbox"/> IP65	<input checked="" type="checkbox"/> IP66	<input type="checkbox"/> IP69			
Position Feedback	<input type="checkbox"/> None	<input type="checkbox"/> Endstop Signal	<input type="checkbox"/> Hall Sensor	<input type="checkbox"/> Potentiometer	<input type="checkbox"/> Encoder	<input checked="" type="checkbox"/> Reed Switches			
Input Voltage	<input type="checkbox"/> 12VDC	<input checked="" type="checkbox"/> 24VDC	<input type="checkbox"/> 36VDC	<input type="checkbox"/> 48VDC	<input type="checkbox"/> 110VAC	<input type="checkbox"/> 220VAC			
Available Certification	<input checked="" type="checkbox"/> CE	<input checked="" type="checkbox"/> UL60601-1	<input checked="" type="checkbox"/> IEC60601-1						

\*Note: Duty Cycle Measurement made with 24VDC stabilized power supply. Max. 10%, Continuous Use 2 minutes followed by 18 minutes not in use.

[Table 1]

Options for MLA-B6     Available Other Models

• Technical Parameters

Code	Spindle Pitch	Max. Dynamic Load - Push*	Max. Dynamic Load - Pull*	Max. Self-Locking Load*	Speed +/-10% (mm/sec)		Typical Amp Full Load (A)
	(mm)				Free Load	Full Load	
A	4	6,000	4,000	6,000	8.5	6	8
B	5	4,000	4,000	4,000	12	9	7
C	5	2,000	2,000	2,000	22	18	8
D	16	500	500	500	75	55	7

[Table 2]

\*Notes:

1. Measurements are made with actuators in connection with stable power supplies and ambient temperature of 20°C. Actual application scenarios should be considered. Please contact cs@machmo.com if your required parameters are not listed.
2. Control Boxes are designed to short circuit the motor terminals (poles) of the actuators when the actuators are not in use. This solution provides self-locking ability. When actuator is not connected to a control box, motor terminals must be short-circuited to allow the actuator to self lock.

Maximum Stroke Length

Max. Dynamic Load (Push) vs. Maximum Stroke	
Push Load (N)	Max. Stroke (mm)
> 6,000	400
> 4,000	500
> 2,000	600
> 500	650

[Table 3]

• Product Dimensions

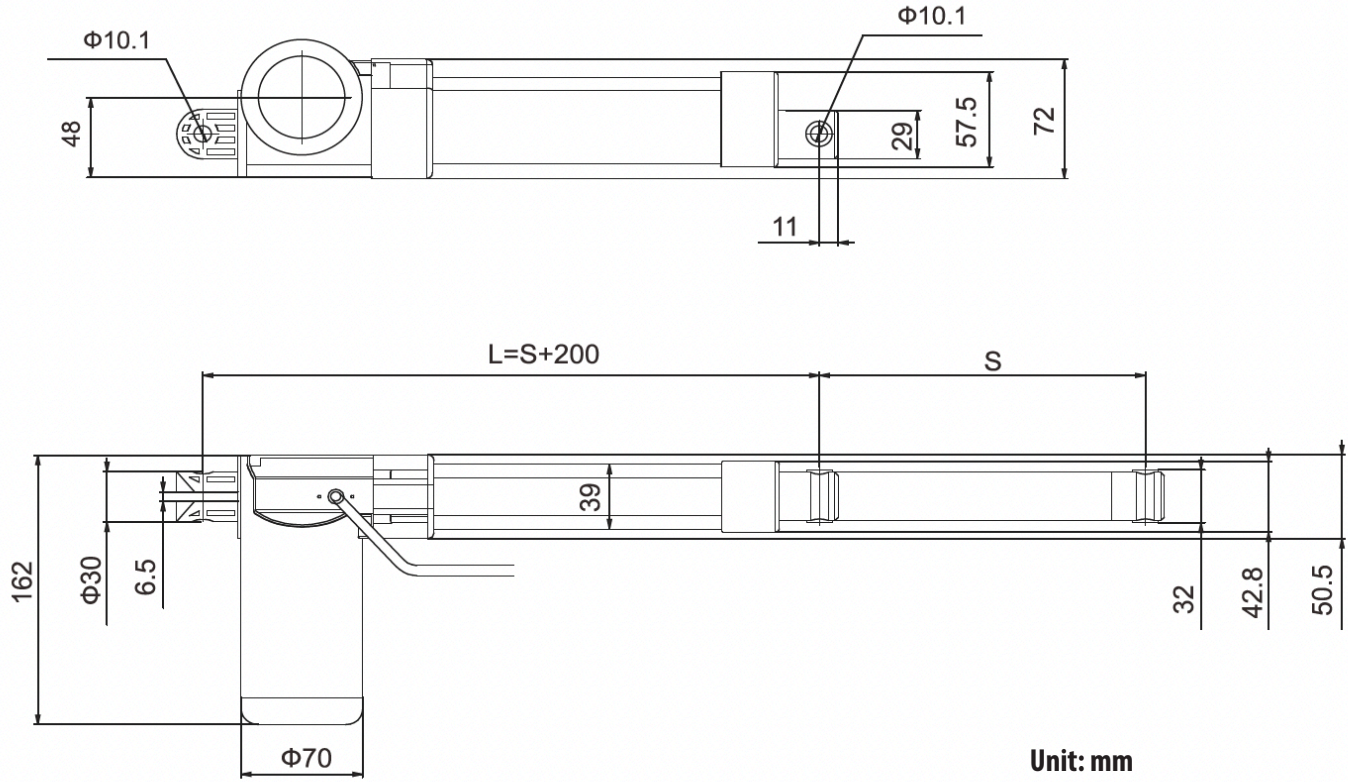

Stroke vs. Installation Length

Stroke (S) (mm)	Installation Length (L) (mm)
50 - 650	$S + 200$

[Table 4]

• Product Inquiry Table

Selection	Specification	Available Options		
<input type="text"/>	Voltage	1 = 24V		
<input type="text"/>	Load and Speed	See [Table 2]		
<input type="text"/>	Stroke (mm)	Please contact <a href="mailto:cs@machmo.com">cs@machmo.com</a> if required stroke is out of range.		
<input type="text"/>	Installation Length (mm)	S + 200mm, See [Table 4]		
<input type="text"/>	Signal Feedback	1 = Reed Switches		
<input type="text"/>	Cable Length	1 = 500mm	2 = 1,000mm	X = Custom
<input type="text"/>	Connector	0 = Tinned Bare Wires	1 = Go with KZ Control	X = Custom
<input type="text"/>	Working Temperature	1 = 5°C ~ 40°C		
<input type="text"/>	Working Frequency	Estimated Work Cycles Per Day		
<input type="text"/>	End Use	Indoor or Outdoor?		

**Application**